

FICHE D'HOMOLOGATION HOMOLOGATION FORM



COMMISSION INTERNATIONALE DE KARTING – FIA



CARROSSERIE / BODYWORK

CARENAGE AVANT / FRONT FAIRING

Constructeur	<i>Manufacturer</i>	BIREL ART
Marque	<i>Make</i>	FREE LINE
Modèle	<i>Model</i>	FL-ANT-F1
Catégorie	<i>Category</i>	Toutes / All
Durée de l'homologation	<i>Validity of the homologation</i>	3 ans / years
Nombre de pages	<i>Number of pages</i>	3

La présente Fiche d'Homologation reproduit descriptions, illustrations et dimensions au moment de l'homologation CIK-FIA.

This Homologation Form reproduces descriptions, illustrations and dimensions at the moment of the CIK-FIA homologation.



PHOTOS VUE DE DEVANT, DE DESSUS ET DE COTÉ, DU CARENAGE AVANT AVEC SUPPORTS

PHOTO FROM FRONT, ABOVE AND SIDE OF FRONT FAIRING WITH SUPPORTS

Signature et tampon de l'ASN

Signature et tampon de la CIK-FIA

Signature and stamp of the ASN

Signature and stamp of the CIK-FIA



CARÉNAGE AVANT AVEC SUPPORTS Dessin technique (dimensions d'encombrement – matériau, diamètre, masse et épaisseur des tubes supports)		FRONT FAIRING WITH SUPPORTS Technical drawing (fairing main external dimensions – supports material, diameter, mass and wall thickness)	
Masse en grammes (Carénage Avant uniquement)	Mass in grams (Front Fairing only)	1500 g	+/-10 %
Masse en grammes Seul le pare-chocs de Carénage Avant	Mass in grams. (Supports for the Front Fairing only)	1250 g	+/-5 %

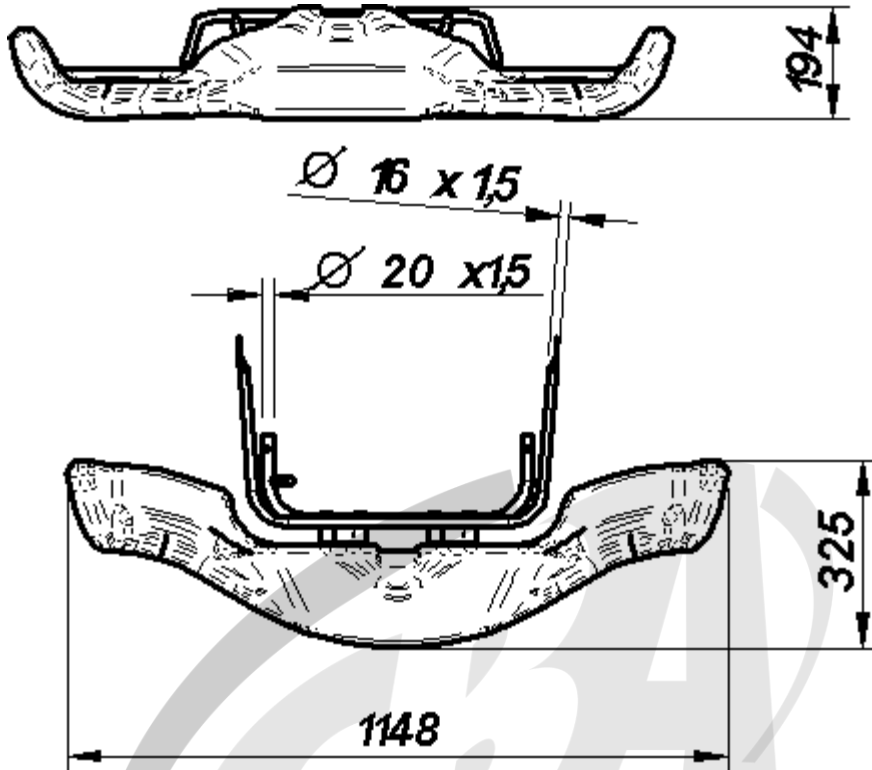

PHOTO: CARENAGE AVANT (complet avec supports) / FRONT FAIRING (complete with supports)



FIXATION CARÉNAGE AVANT

Dessin technique éclaté

FRONT FAIRING ATTACHMENT*Exploded technical drawing*

PHOTO DU MARQUAGE DU NUMERO
D'HOMOLOGATION (et du logo CIK-FIA sur les
éléments plastiques et supports)

PHOTO OF THE HOMOLOGATION NUMBER
MARKING (and of the CIK-FIA logo on the
plastic parts and supports)

Le marquage doit rester clairement visible en permanence
The marking must be clearly visible at all times

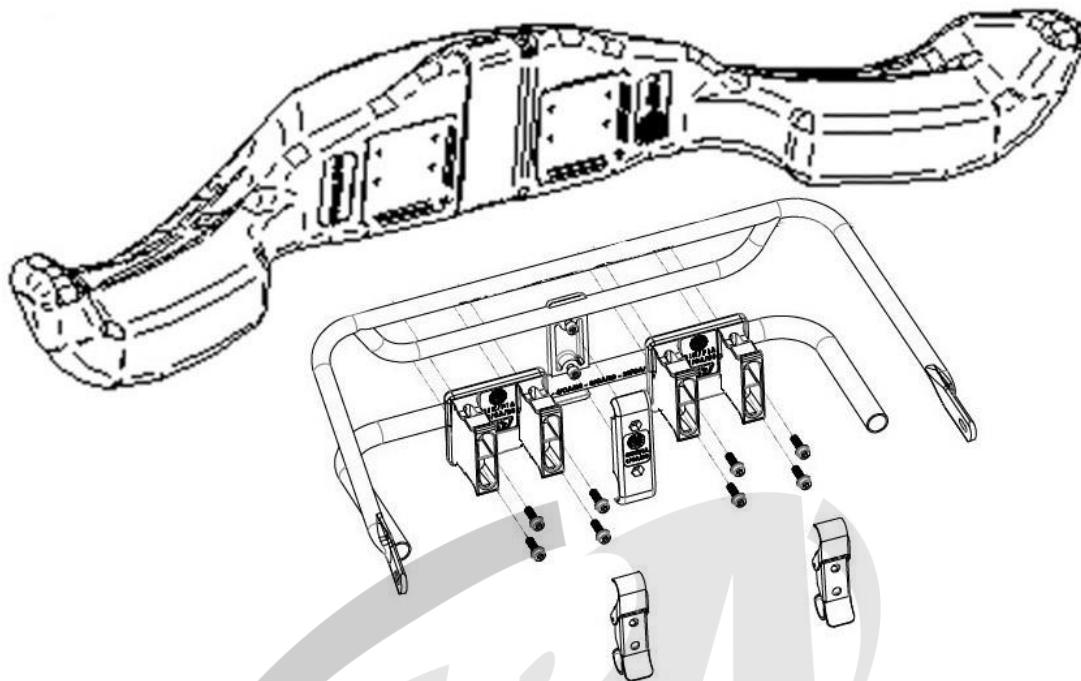